

JHS-431

**INTRINSICALLY SAFE
UHF TRANSCEIVER**

**INSTRUCTION
MANUAL**

JRC *Japan Radio Co., Ltd.*

INTRINSIC SAFETY



Versions of the JHS-431 which display the “EX” marking on the serial number seal.

The approval rating for these models are II2G Ex ib IIA T3 Gb and II 2D Ex tb IIIC T160°C Db IP67.

WARNING! NEVER charge the BP-227AXD (with/without the transceiver) in an explosive atmosphere. The optional battery chargers are not approved as Intrinsically Safe.

When the transceiver is used in a hazardous area, the BP-227AXD **MUST** be attached, either the jack cover or HM-138 **MUST** be attached to the speaker-microphone connector.

KEEP the transceiver and the BP-227AXD clean to avoid any risk of ignition due to the build-up of electrostatic charges.

Repair of JRC radios should only be carried out by authorized JRC distributors. In particular, repair of ATEX approved radios can **ONLY** be done by JRC to maintain the intrinsically safe rating. **NEVER** attempt to repair an ATEX approved radio. Only JRC has the repair expertise and procedures to maintain the ATEX approval. Contact your JRC distributor or authorised dealer for details.

The equipment can be used without the microphone but with the jack cover.

The ATEX standard is described on the 94/9/EC sticker (Ex Marking) and BP-227AXD as below.

*The following illustrations show the JHS-431.

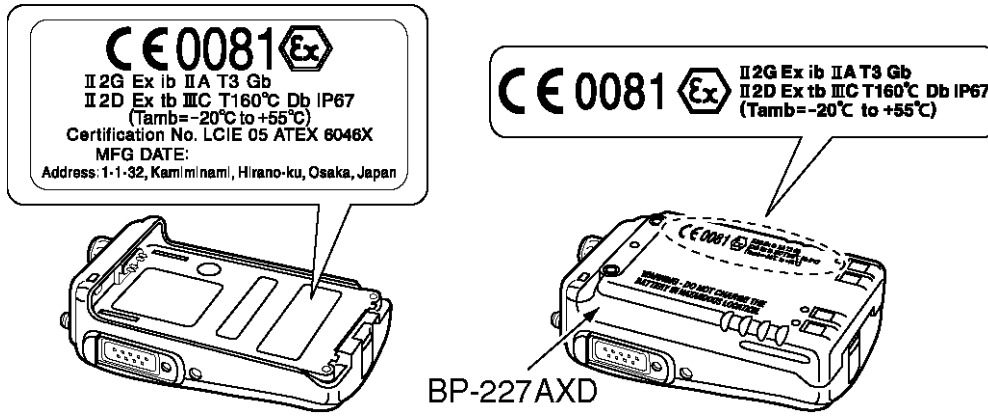

- DO NOT OPEN WHEN AN EXPLOSIVE ATMOSPHERE MAY BE PRESENT.
- DO NOT CHARGE THE BATTERY IN HAZARDOUS LOCATION.

Preface



Thank you for purchasing the JRC intrinsically safe UHF transceiver JHS-431. The JHS-431 is an intrinsically safe on-board vessels communication transceiver of 400 MHz band 2-watt output. It is suitable for inboard, ship-to-ship, ship-to-shore, and pier-to-pier telecommunications in moving a ship, loading or unloading, life saving, going alongside the pier, mooring, and so on.

Before Operation

Concerning the symbols

This manual uses the following symbols to explain correct operation and to prevent injury or damage to property.

The symbols and descriptions are as follows. Understand them before proceeding with this manual.

	DANGER	This safety reminder is given to items that are potentially dangerous to life. If these items are done improperly, you will be seriously injured and in extreme cases, you will be put to death.
	WARNING	This safety reminder is given to items that are potentially dangerous to your body. If these items are done improperly, you may be injured and in extreme cases, you may be put to death.
	CAUTION	This safety reminder is given to items that are potentially dangerous to your body or property. If these items are done improperly, you will be injured and property will be damaged.

Examples of symbols



Electric shocks

This triangle mark contains an item you must pay attention to (caution, warning or danger). This example tells "Be careful not to get an electric shock."



No disassemble



Prohibit

This mark contains an item you must not do and has an explanation under it. This example tells "Never disassemble."



Pull plug out



Instruction

This mark contains an item you must do. This example tells "Disconnect the power plug from the outlet."

SAFETY TRAINING INFORMATION



WARNING

Your radio generates RF electromagnetic energy during transmit mode. This radio is designed for and classified as "Occupational Use Only", meaning it must be used only during the course of employment by individuals aware of the hazards, and the ways to minimize such hazards. This radio is NOT intended for use by the "General Population" in an uncontrolled environment.

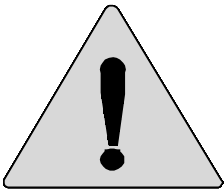

CAUTION

Electromagnetic Interference/Compatibility

During transmissions, your radio generates RF energy that can possibly cause interference with other devices or systems. To avoid such interference, turn off the radio in areas where signs are posted to do so.

DO NOT operate the transmitter in areas that are sensitive to electromagnetic radiation such as hospitals, aircraft, and blasting sites.

Occupational/Controlled Use

The radio transmitter is used in situations in which persons are exposed as consequence of their employment provided those persons are fully aware of the potential for exposure and can exercise control over their exposure.

Foreword

READ ALL INSTRUCTIONS carefully and completely before using the transceiver.

SAVE THIS INSTRUCTION MANUAL-This instruction manual contains important operating instructions for the JHS-431 UHF TRANSCEIVER.

Explicit Definition

Word Definition

WARNING:Personal injury, fire hazard or electric shock may occur.

CAUTION:Equipment damage may occur.

NOTE:If disregarded, inconvenience only. No risk of personal injury, fire or electric shock.

Operating Notes

- When transmitting with a portable radio, hold the radio in a vertical position with its microphone 5 to 10 centimeters (2 to 4 inches) away from your mouth. Keep the antenna at least 2.5 centimeters (1 inch) from your head and body.
- If you wear a portable two-way radio on your body, ensure that the antenna is at least 2.5 centimeters (1 inch) from your body when transmitting.

Precaution

WARNING! NEVER hold the transceiver so that the antenna is very close to, or touching exposed parts of the body, especially the face or eyes, while transmitting. The transceiver will perform best if the microphone is 5 to 10 cm (2 to 4 inches) away from the lips and the transceiver is vertical.

WARNING! NEVER operate the transceiver with audio accessories at high volume levels.

CAUTION! NEVER short the terminals of the battery pack.

NEVER connect the transceiver to a power source other than the BP-227AXD. Such a connection will ruin the transceiver.

DO NOT push the PTT when not actually desiring to transmit.

AVOID using or placing the transceiver in direct sunlight or in areas with temperatures below -20°C (-4°F) or above $+60^{\circ}\text{C}$ ($+140^{\circ}\text{F}$).

DO NOT modify the transceiver for any reason.

MAKE SURE the flexible antenna and battery pack are securely attached to the transceiver, and that the antenna and battery pack are dry before attachment. Exposing the inside of the transceiver to water will result in serious damage to the transceiver. The use of non-BP-227AXD battery packs/chargers may impair transceiver performance and invalidate the warranty.

Handling precaution



DANGER



The NZB-139/NZB-141/NZB-142 battery chargers are not intrinsically safe type. Do not keep or use the NZB-139/NZB-141/NZB-142 in the presence of any explosive or combustible gas (*1). It may cause an explosion or fire.



Only a few kinds of explosive gases and vapors are defined to be non-harmful to the JHS-431. Do not use the JHS-431 in the presence of any other explosive or combustible gas. It may cause an explosion or fire.



Always use the dedicated battery pack (BP-227AXD) of the JHS-431. When other battery pack is used, it may cause an explosion or fire.



Never disassemble, remodel, or repair the JHS-431 and its components. It may cause a fire or failure. Particularly, disassembling in the presence of any explosive or combustible gas may cause an explosion or fire.



Do not replace the battery pack in the presence of any explosive or combustible gas. Replacing in such a hazardous area may cause an explosion or fire.



If the JHS-431 is dropped to the ground or damaged, send it to your local JRC distributor or sales office for check and repairing. Do not use it in the presence of any explosive or combustible gas. Using the broken product in a hazardous area may cause an explosion or fire.

*1 "in the presence of any explosive or combustible gas" is also called "in a hazardous area." This atmosphere may contain or contains a critical amount of combustible gas or explosive vapor that may quickly explode or make a fire by an electric spark or high temperature.



WARNING



Do not put the battery pack in a microwave oven or in a high-pressure container. The battery pack may leak its content, become hot, or explode.



If the content of the battery pack jumps into your eyes, do not rub. This risks corneal damage. Try washing with running water. Then, consult your doctor.



Do not disassemble or remodel the battery pack. This may cause the battery pack to explode, to overheat, ignite or to leak the harmful content (organic solvent).



Do not solder wires directly to the charging and output terminals of the battery pack. This may cause the battery pack to explode, to overheat, ignite or to leak the harmful content (organic solvent).



Do not short-connect the charging terminals of the charger. The short-connected terminals will cause a fire or failure.



When finding the charger troubled, pull out the plug from the outlet, then call your local JRC distributor or sales office. Never use the disabled charger. It may cause a fire or give you electric shocks.



Do not throw the battery pack into fire. Fire and heat may cause the battery pack to explode, to overheat, ignite or to leak the harmful content (organic solvent).



CAUTION



Always use the dedicated battery pack (BP-227AXD) of the JHS-431. When other battery pack is used, the performance and operation of the JHS-431 will not be assured.



Charge the battery pack in the ambient temperature range of 10°C to 40°C. Never charge when the temperature is below 0°C. A gas generated in the battery will cause the safety valve to actuate and shorten the battery life. Further, it causes the protective circuit of the charger to work and disables the charger to charge.



For installation, checking, maintenance, and repairing of the product, call your local JRC distributor or sales office. Servicing by unauthorized personnel results in malfunction or failure of the product.



Always follow the instructions in this manual. By wrong and improper handling, you cannot enjoy the performance of the JHS-431.



Always use the dedicated charger (NZZ-139/NZZ-141/NZZ-142) to charge the battery pack.



Be sure to turn off the power switch of the JHS-431 to save the battery power and have a longer battery life.

Contents

Preface	iii
Before operation	iv
Handling precaution	vii
1 General	1
2 Features	1
3 Composition	2
3.1 Standard composition	2
3.2 Options	2
4 Accessories	2
4.1 Accessory attachments	2
5 Panel Description	4
5.1 Front, top and side panels	4
5.2 Function display	4
5.3 Function keys	5
6 Battery Charging	6
6.1 Battery charging	6
6.2 Optional battery chargers	7
7 Speaker/Microphone	8
7.1 Optional HM-138 description	8
7.2 Attachment	8
8 ATEX CAUTIONS	9
8.1 Special conditions for safe use	9
8.2 Meaning of ATEX marking codes	9
9 Maintenance	11
9.1 Daily Maintenance	11
9.2 Regular Inspection	11

10 After-Sale Services 12

10.1 Repair during the warranty period 12

10.2 Repair after the warranty period 12

10.3 Items to be informed 12

11 Specifications 13

11.1 General 13

11.2 Transmitter 13

11.3 Receiver 13

11.4 Tone Squelch 14



1 General

The JHS-431 is an intrinsically safe 400 MHz band UHF 2-watt output maritime transceiver. It is suitable for inboard, ship-to-ship, ship-to-shore, and pier-to-pier telecommunications in moving a ship, loading or unloading, life saving, going alongside the pier, mooring, and so on.

2 Features

The JHS-431 offers a compact waterproof package that is easy to use. This radio keeps you in contact in nearly any environment.

- **JIS Grade 7 Waterproof protection**
The gasket sealed waterproof housing provides superior waterproof protection, equivalent to JIS Grade 7*.
* Equivalent to IPX7 of corresponding international standard IEC 529 (1989). 1m depth for 30 minutes.
- **Built-in Tone Squelch**
Use the built-in CTCSS capability to set up your own talk groups and quiet stand-by when others are talking.
- **Intrinsically Safe**
Intrinsically safe approved by the FM Global Technologies LLC, is suitable for use in hazardous areas where flammable gasses or liquids are used. See specification page for applied classes.
- **Li-Ion battery pack**
The large capacity 1700mAh Lithium-Ion(Li-Ion) battery pack, BP-227AXD provides a practical 10 hours* of operating time. Li-Ion batteries allow flexible charging and have almost no memory effect.
* Typical operation Tx:Rx:Stand-by = 1:1:18
- **Compact body**
56(W)x97(H)x36.4(D)mm compact body with durable, dependable construction, meets MIL standard specifications.
- **Other features**
Built-in audio compander Powerful 2W output 2 step power saver

 DANGER	
	Only a few kinds of explosive gases and vapors are defined to be non-harmful to the JHS-431. Do not use the JHS-431 in the presence of any other explosive or combustible gas. It may cause an explosion or fire.

3 Composition

3.1 Standard composition

No.	Item	Model	Qty	Notes
1	Transceiver	JHS-431	1	
2	Antenna	FA-S27U	1	Whip antenna
3	Battery pack	BP-227AXD	1	Li-Ion battery (nominal 7.4V,1850mAH)
4	Belt clip	MB-79	1	
5	Carrying strap	MB-80	1	
6	Instruction manual	7ZPJD0566	1	English
7	Instruction manual	A-6955H-1EU	1	A6 size English For reference
8	Inspection data		1	

3.2 Options

No.	Product Name	Model	Notes
1	External speaker / Microphone	HM-138	Water-proof type
2	Carrying case	MPXP33443A	Genuine leather
3	Spare battery pack	BP-227AXD	Li-Ion battery (nominal 7.4V,1850mAH)
4	Spare antenna	FA-S27U	Whip antenna
5	Battery Charger	NZB-139	Desktop mount, 100V-240V AC, 30VA
6	Multi Battery Charger	NZB-141	Wall mount, 100V-240V AC, 100VA (up to 6 pcs)
7	Multi Battery Charger	NZB-142	Desktop mount, 100V-240V AC, 100VA (up to 6 pcs)
8	Antenna	NAU-6	For non-powered antenna system (for both indoor and outdoor use, with an N connector)
9	Antenna	NAU-3C	For non-powered antenna system (for indoor use, with an BNC connector)

4 Accessories

4.1 Accessory attachment

Whip antenna

Connect the supplied whip antenna to the antenna connector.

CAUTION!

NEVER HOLD by the antenna when carrying the transceiver.
Transmitting without an antenna may damage the transceiver.

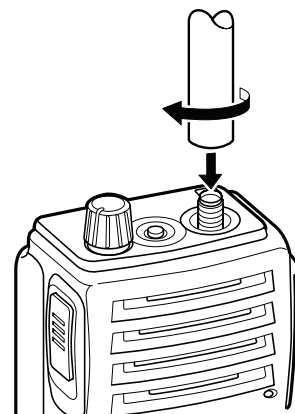

Battery pack

To attach the battery pack:

Slide the battery pack on the back of the transceiver in the direction of the arrow (①), then lock it with the battery release button.

Slide the battery pack until the battery release button makes a 'click' sound.

To release the battery pack:

Push the battery release button in the direction of the arrow (②) as shown right. The battery pack is then released.

NEVER release or attach the battery pack in a hazardous area. This may result cause an explosion or fire.

NEVER release or attach the battery pack when the transceiver is wet or soiled. This may result water or dust getting into the transceiver/battery pack and may result in the transceiver being damaged.

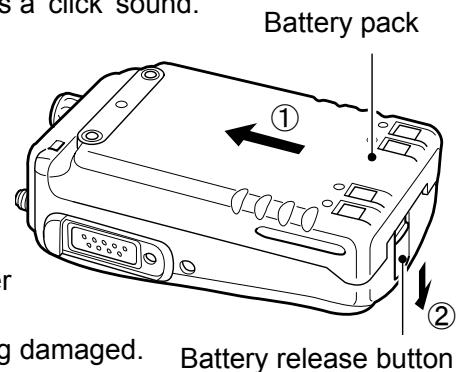

Jack cover

Attach the jack cover when the optional speaker-microphone is not used.

To attach the jack cover:

- ① Insert the jack cover into the [SP MIC] connector.
- ② Tighten the screw.

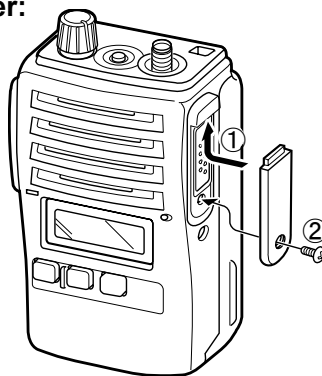

To detach the jack cover:

- ③ Unscrew the screw with a phillips screwdriver.
- ④ Detach the jack cover for the speaker/microphone connection.

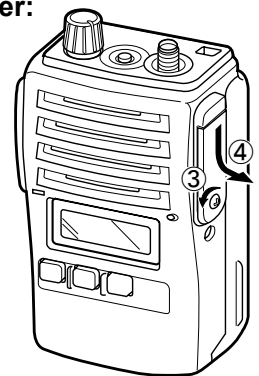

Belt clip

Attach the belt clip to the back of the transceiver with the supplied screws.

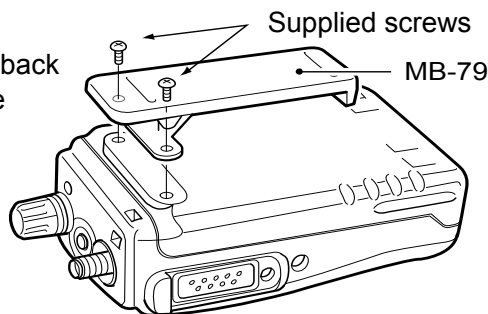

Carrying strap

Attach the Carrying strap to the back of the transceiver with the supplied screws.

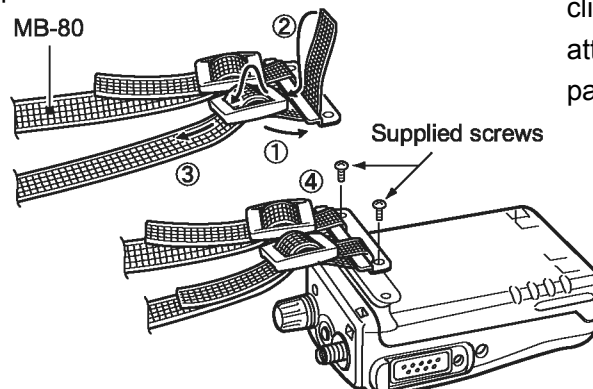

NOTE:

In replacing a battery pack. Belt clip and carrying strap are removed from an old battery pack, and please reattach to a new battery pack. Neither belt clip nor carrying strap is attached to a new battery pack.

5 Panel Description

5.1 Front, top and side panels

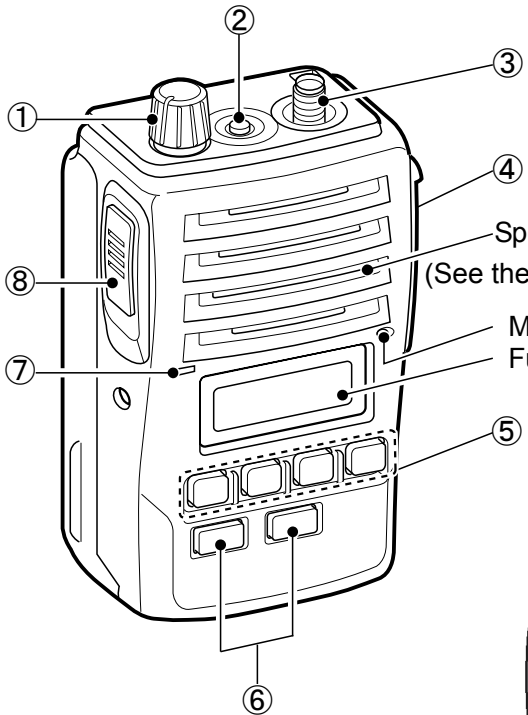

- ① VOLUME CONTROL [VOL]
Turns power ON and adjusts the audio level.
- ② RED BUTTON [RED]
Monitor (See P.5 for details)
- ③ ANTENNA CONNECTOR
Connects the supplied antenna.

- ④ SPEAKER-MICROPHONE CONNECTOR [SP MIC]
Connects the optional speaker-microphone.(p.8)

- ⑤ FUNCTION KEYS
[P0] to [P3] (See P.6 for details)
- ⑥ CH UP AND DOWN KEYS ▲ ▼
During standby condition, push to select an operating channel.
- ⑦ TRANSMIT/BUSY INDICATOR
Lights red while transmitting; lights green while receiving a signal, or when the squelch is open.
- ⑧ PTT SWITCH [PTT]
Push and hold to transmit; release to receive.

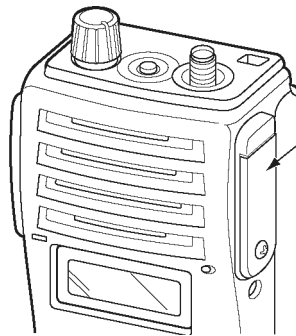

[SP MIC] jack cover
NOTE: KEEP the [SP MIC] jack cover attached to the transceiver when the speaker/microphone is not used. (See p.3 for details)

NOTE:
If the speaker netting (for dust proofing) becomes wet, dry it with a hair drier (cool mode) etc. before operating the transceiver. Otherwise the audio may be difficult to hear for loss of the sound pressure.

5.2 Function display

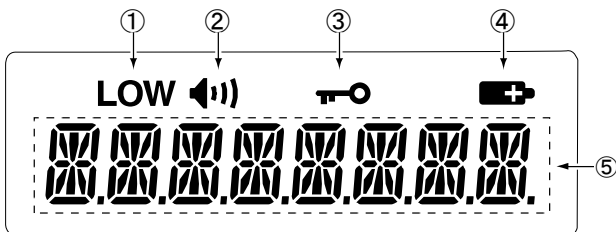

- ① OUTPUT POWER INDICATOR
Appears when Low 2 or Low 1 is selected.
- ② AUDIBLE INDICATOR
Appears when "Tone SQL" is released.
- ③ KEY LOCK INDICATOR
Appears during the key lock function ON.

- ④ BATTERY INDICATOR
Appears or blinks when the battery power decreases to a specified level.
- ⑤ ALPHANUMERIC DISPLAY
Displays the operating channel number, tone squelch number, set mode contents, etc.

5.3 Function keys

The following functions can be assigned to [P0], [P1], [P2], [P3],[RED], ▲ and ▼ function keys. If the function names are bracketed in the following explanations, the specific switch used to activate the function depends on programming.

[P0] Key - MONITOR - also [RED BUTTON]

While in the standby condition and while pushing and holding [P0] key,TSQL and SQL are released.
(OFF Position) (Sp mark appears and lights green LED)
After release [P0] key, only SQL is set.
Push [P0] key momentarily to set TSQL and SQL.
[RED] button on the top of the transceiver has the same function as [P0] key.

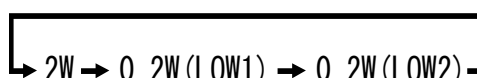
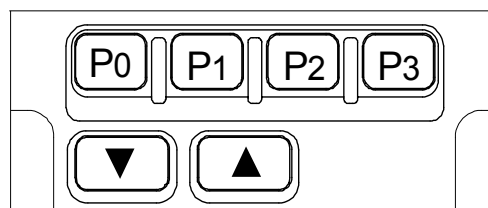

[P1] Key - OUTPUT POWER SELECTION -

While in the standby condition, push [P1] key to select output power in rotation as the diagram.

[P2] Key - SET MODE -

While in the standby condition, push and hold [P2] key to enter user set mode.
Push [P2] key momentarily to select the item.
Then push [] and [] to set the desired level / condition.

Available set mode functions:

- Backlight : ON, Automatic or OFF
- Beep : ON or OFF
- SQL Level : 0 to 255
- AF Min level : ON or OFF
- Battery Voltage : ON or OFF

Push and hold [P2] again to exit set mode.

Set Mode

LIGHT	LIGHT ON	Normally light On
	LIGHT AUT	Automatically light On/Off
	LIGHT OFF	Normally light Off
BEEP	BEEP ON	Normally beep On
	BEEP OFF	Normally beep Off
SQ	SQL 255	Use for strong signal
	SQL 0	Use for weak signal
AFMIN	AFMINON	Volume is remained when set the volume knob to the minimum
	AFMINOFF	
BATT	BATT ON	Sound level follows volume knob
	BATT OFF	When turn on the power SW, the battery voltage appears in the display No battery voltage display

[P3] Key - LOCK -

While in the standby condition, push and hold [P3] key to lock the keyboards.(Appears key mark.)

Push and hold [P3] again to exit key lock mode. (Disappears key mark.)

CH UP AND DOWN KEYS

- ▲ Push this key to select the desired CH or items upward.
- ▼ Push this key to select the desired CH or items downward.

6 Battery Charging

6.1 Battery charging



WARNING



Do not replace the battery pack by a new one in the presence of any explosive or combustible gas. Disassembling in such a hazardous area may cause an explosion or fire.



Do not short-connect the terminals of the battery pack. Do not throw the battery pack into fire. Do not disassemble or alter the battery pack. The battery pack may cause an explosion or fire in a hazardous area.

ATTENTION

Wipe clean the terminals of the battery pack with a clean soft cloth if they are stained (to assure charging and complete terminal contact).



DANGER



The battery charger is not intrinsically safe. Do not place or use in the presence of any explosive or combustible gas (or in a hazardous area) to prevent explosion or fire.

Prior to using the transceiver for the first time, the battery pack must be fully charged for optimum life and operation.

CAUTION!

To avoid damage to the transceiver, turn it OFF while charging.

① Recommended temperature range for charging:

Recommended temperature range for charging: +0°C to +40°C (+32°F to +104°F)
The Li-Ion battery functions within -20°C to +60°C (-4°F to +140°F).

② Use the specified chargers

(NZZ-139, NZZ-141 and NZZ-142).

③ **NEVER** use another manufacturer's charger.

④ **NEVER** use another manufacturer's AC adapter.

Recommendation: Charge the supplied battery pack for a maximum of up to 10 hours. Li-Ion batteries are different from Ni-Cd batteries in that it is not necessary to completely charge and discharge them to prolong the battery life. Therefore, charging the battery in intervals, and not for extended periods is recommended.

CAUTION!

NEVER insert battery pack/transceiver (with the battery pack attached) with wet or soiled into the charger. This may result in corrosion of the charger terminals or damage to the charger. The charger is not waterproof and water can easily get into it.

NEVER incinerate used battery packs. Internal battery gas may cause an explosion.

NEVER immerse the battery pack in water. If the battery pack becomes wet, be sure to wipe it dry immediately (particularly the battery terminals) **BEFORE** attaching it to the transceiver. Otherwise, the terminals will become corroded, or cause connection failure, etc.

AVOID leaving the battery pack in a fully charged, or completely discharged condition for long time. It causes shorter battery life. In case of leaving the battery pack unused for a long time, it must be kept safely after discharge, or use the battery until the battery indicator appears, then remove it from the transceiver. If your battery pack seems to have no capacity even after being charged, fully charge the battery pack again. If the battery pack still does not retain a charge (or very little), a new battery pack must be purchased.



Li-ion

After use is to recycling.

In order to reuse a rare metal and to maintain earth environment. The battery which became unnecessary is not discarded. Please bring to a charge type battery recycling cooperation store.

6.2 Optional battery chargers

① Rapid charging with the NZB-139

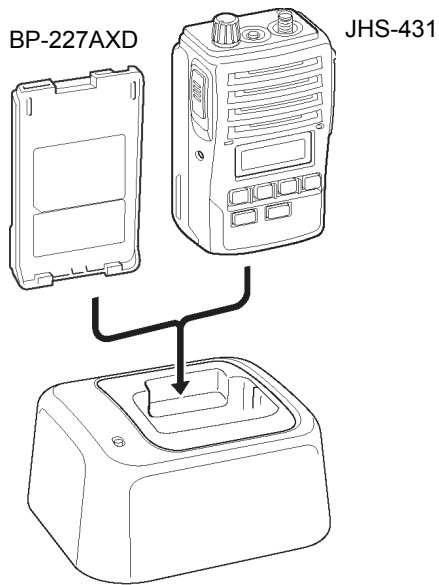

The optional NZB-139 provides rapid charging of battery pack or JHS-431 (with the battery pack attached).

Charging time: approx. 2 to 2.5 hours

② Rapid charging with the NZB-141/NZB-142

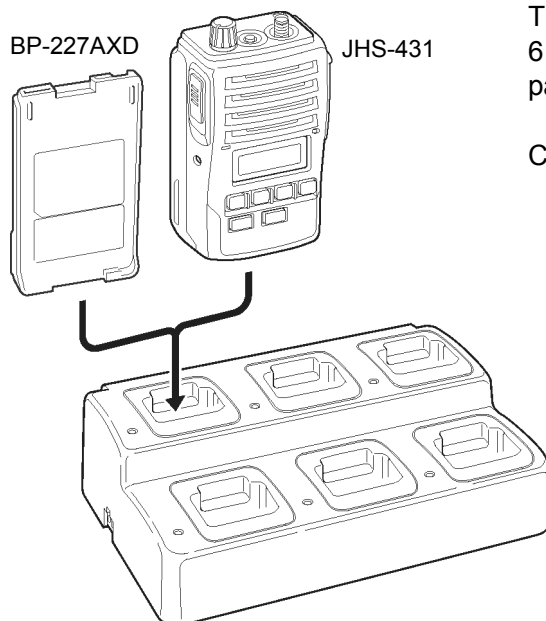

The optional NZB-141/NZB-142 allow up to 6 battery packs or JHS-431 (with the battery pack attached) to be charged simultaneously.

Charging time: approx. 2 to 2.5 hours

Charging indicator

- Lights orange while charging
- Lights green when charging is completed
- Blinks orange or green, or does not light when a problem is detected

SOLUTIONS:

- Remove the battery pack, and reinsert it.
- Remove the battery pack, clean the battery terminals, then reinsert it.
- If the battery pack temperature is high, remove and let it cool down, then reinsert it.

If you are unable to solve the problem through the use of these solutions, the battery pack or the charger may be damaged, or the battery life may be over. In that case, contact your nearest JRC Dealer or Service Center.

7 Speaker/Microphone

7.1 Optional HM-138 description

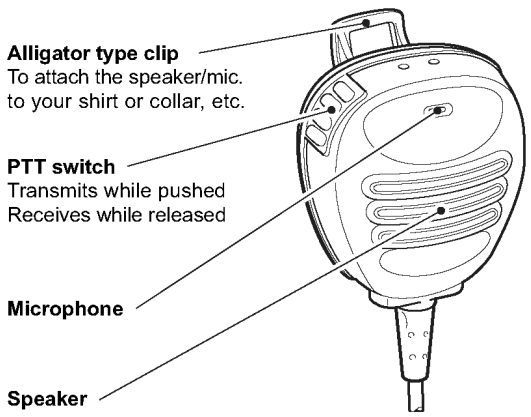

NEVER immerse the connector in water. If the connector becomes wet, be sure to dry it **BEFORE** attaching it to the transceiver.

NOTE: The microphone is located at the top of the speaker/microphone, as shown in the diagram left. To maximize the readability of your transmitted signal (voice), hold the microphone approx. 5 to 10 cm (2 to 4 inches) from your mouth, and speak in a normal voice level.

7.2 Attachment

Attach the connector of the speaker/microphone into the [SP MIC] connector on the transceiver and tighten the screw.

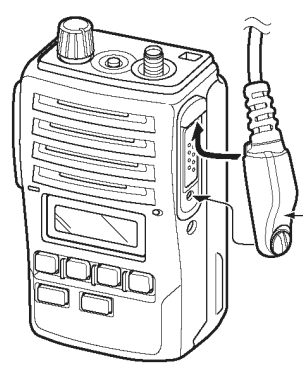

IMPORTANT: KEEP the [SP MIC] jack cover attached (transceiver) when the speaker/microphone is not in use. Water will not get into the transceiver even if the cover is not attached, however, the terminals (pins) will become rusty, or the transceiver will function abnormally if the connector becomes wet.

CAUTION: Attach the speaker/microphone's connector securely to prevent accidental dropping, or water intrusion in the connector.

CAUTION: For ATEX compliance in hazardous areas, the jackcover just also be attached when the HM-138 is not being used.

8 ATEX CAUTIONS

8.1 Special conditions for safe use

The equipment is an intrinsically safe equipment. It can be used in a potentially explosive atmosphere.

The equipment must be powered only by the battery JRC type BP-227AXD.

When the transceiver is used in a hazardous areas, either the jack cover or HM-138 must be attached to the connector. Failure to do this will make the radio ATEX non-compliant and may result in an accident during use in hazardous areas.

The battery shall be charged only in non hazardous areas.

Ambient operating temperature: -20°C to +55°C

8.2 Meaning of ATEX marking codes



Ambient temperature

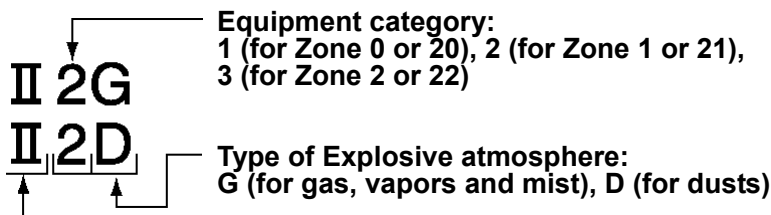
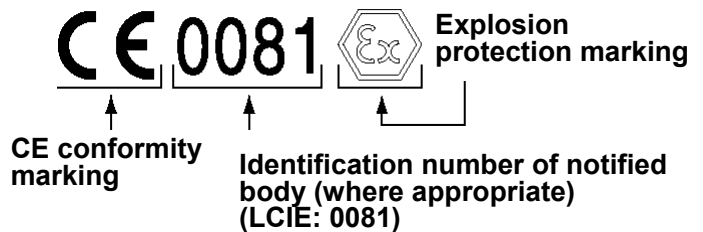

Equipment group: I(for mines), II(for other than mines)

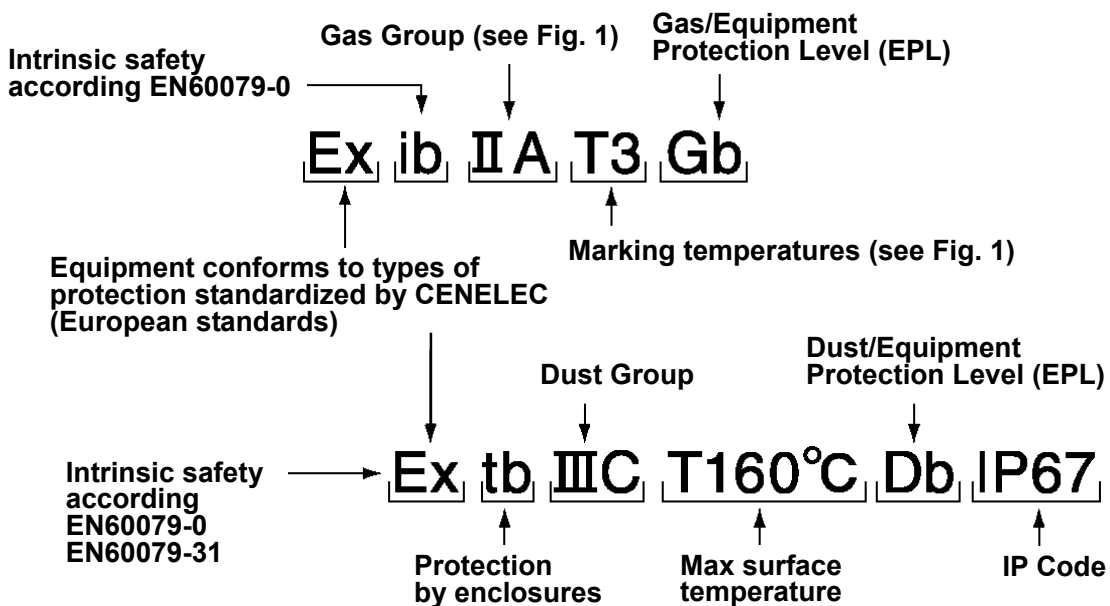

		Max. Temperature					
		T1: 450°C	T2: 300°C	T3: 200°C	T4: 135°C	T5: 100°C	T6: 85°C
Gas Group	I	Methane	—	—	—	—	—
	II A	Acetone	Ethyl alcohol	Benzine	Acetalde hyde	—	—
		Ethane	I-amyl acetate	Diesel fuel	Ethyl ether	—	—
		Ethyl acetate	n-butane	Aircraft fuel	—	—	—
		Ammonia	n-butyl alcohol	Heating oil	—	—	—
		Benzene (pure)	—	n-hexane	—	—	—
		Acetic acid	—	—	—	—	—
		Carbon Monoxide	—	—	—	—	—
		Methanol	—	—	—	—	—
		Propane	—	—	—	—	—
	Toluene	—	—	—	—	—	
	II B	Town Gas (Coal Gas)	Ethylene	—	—	—	—
	II C	Hydrogen	Acetylene	—	—	Carbon disulphide	Ethyl nitrate

(Fig.1)

9 Maintenance

9.1 Daily Maintenance

Daily checks and periodic maintenance are recommended for you to enjoy the long steady performance of the JHS-431. Those may enable earlier detection of problems and prevent the problems from propagating. Table 9-1 lists recommended checks.

Table 9-1

Step	Check point	Description
1	Battery	Make sure the Battery indicator does not light or blink on the display of the JHS-431. If the Battery indicator lights or blinks, charge the battery.
2	PWR/VOL control	Turn the control and make sure that the JHS-431 is powered on and off and that the voice volume varies smoothly.
3	P0 Key (Monitor)	Set this switch to the OFF position and make sure you hear noises. (See P.6 for details)
4	Transmitter output	Make sure the Transmit indicator lights while the JHS-431 is transmitting.
5	Transmitting condition	Make sure your JHS-431 can normally talk to and hear from the remote station.
6	Charging terminals	Make sure the charging terminals are clean. If not, wipe them clean with soft cloth or the like.

9.2 Regular Inspection

Perform one or more transmission tests every month and check the functions of the JHS-431.



CAUTION



If finding any transceiver problem, call your local JRC distributor or sales office. Do not let any unqualified personnel disassemble and repair the JHS-431. If done, the operation and the function of the JHS-431 will not be assured.

10 After-Sale Services

In the event of a failure of the product, first check your operation and battery.

If the failure cannot be removed, suspend using the product and call your local JRC distributor or sales office.

10.1 Repair during the warranty period

If JRC inspection shows that the problem was caused by defective material or workmanship within the limitations of the warranty, JRC will repair or replace the product free of charge. Repairs made necessary by normal wear, abnormal use, fires or disasters, if they can be made, will be charged at regular factory prices.

10.2 Repair after the warranty period

Repairs of the product outside the warranty period, if they can be made, will be charged at regular factory prices.

10.3 Items to be informed

- Product name, Model name, Date of manufacture, and Serial number
- A written statement about the nature of the problem (in detail)
- Your name, address, and phone number.

Recommended inspection and maintenance

It usually happens that the performance of your product will be lower as time goes by although it is dependent upon the conditions of use. We recommend it to be overhauled by the JRC qualified personnel (charged). For more information, call your local JRC distributor or sales office.

11 Specifications

11.1 General

Intrinsically safe:

ATEX Directive 94/9/EC

II2G Ex ib IIA T3 Gb

II2D Ex tb IIIC T160°C Db IP67

Connected battery pack: BP-227AXD

Standard frequencies:

CH1 457.525MHz

CH2 457.550MHz

CH3 457.575MHz

Optional frequencies:

(CH4 467.525MHz)

(CH5 467.550MHz)

(CH6 467.575MHz)

Communication mode:

Simplex

Type of emission:

F3E(G3E)

Antenna:

Whip antenna, non-directional
(nominal 50 Ω unbalanced)

Power source:

Li-Ion battery (7.4V,1850mAH)

Consumption current:

Transmission: Approx. 1.1A

Reception: Approx. 300mA

Standby: Approx. 85mA

Operating temperature:

-20°C to +60°C

(-20°C to +55°C for Intrinsically safe)

(+0°C to +40°C for charging)

(Range of performance guarantee in
transceiver unit is +5°C to +35°C)

Continuous service time:

Approx 10 hours

(*Typical operation

Tx:Rx: Standby =1:1:18)

Compass safe distance:

0.7 meter

Humidity:

+35°C, 95% RH

Water-proof:

1 meter under the surface of water
for 30 min.

Dimensions:

56 mm(W)~97 mm(H)~36.4 mm(D)

(excluding projections)

Mass: Approx. 285 g

(including the battery pack)

11.2 Transmitter

Output power:

2 watt + 0%, -50%

(Low Power mode :

less than 0.2 watt)

Frequency accuracy:

Within $\pm 5 \times 10^{-6}$ or less

Oscillator:

PLL frequency synthesizer

Modulation:

Variable reactance frequency
modulation Maximum frequency

Deviation:

Within ± 5 kHz

Modulation frequency:

300 Hz to 3000 Hz

Spurious emission:

2.5 μ W or less

Occupied frequency band width:

16 kHz or less

Total distortion and noise:

20 dB or more in standard modulation

Modulation input impedance:

2.2 kΩ

Standard modulation input level:

Approx. 15 mV

11.3 Receiver

Receiving system:

Double superheterodyne

Intermediate frequencies:

1st:46.35 MHz, 2nd: 450 kHz

Local oscillation frequency:

1st Lo Reception frequency

-46.35 MHz

2nd Lo: 45.9 MHz

Radiation:

2 nW or less

Local frequency stability:

Within $\pm 5 \times 10^{-6}$ or less

Sensitivity:

8 dB μ (2.5 μ V) or less by 20dB NQS

Total distortion and noise:

20 dB or more

Demodulation Frequency:

300 Hz to 3000 Hz

Rated AF output:

Approx. 350 mW

Speaker impedance:

8 Ω

11.4 Tone Squelch

Tone frequency deviation:	Standard ± 0.5 kHz, Maximum ± 0.9 kHz
Tone signal frequency error:	$\pm 0.5\%$ or less
Tone signal rise time:	Maximum 0.5 second or less
Tone signal distortion:	20 dB or more
Tone squelch open sensitivity:	Receiver input voltage or less required to suppress noises by 10 dB
Signal to noise ratio of received signal:	30 dB or more
Tone frequencies:	See the table below. (max. 2 tones)

Station type	Class	Tone signal frequency (Hz)			
Ship station	A	107.2	114.8	123.0	131.8
	B	141.3	151.4	162.2	173.8
	C	186.2	203.5	218.1	233.6
	D	103.5	110.9	118.8	127.3
	E	136.5	146.2	156.7	167.9
	F	179.9	192.8	210.7	225.7
On-board communication station (For pilot and tug boat communication in moving a ship, going alongside the pier, mooring, and so on.)		67.0	77.0	88.5	(One tone for each selected area of use)

Attached Outline Drawings

JHS-431	UHF TRANSCEIVER
BP-227AXD	BATTERY PACK
HM-138	EXTERNAL SPEAKER / MICROPHONE
MPXP33443A	CARRYING CASE
NZB-139	BATTERY CHARGER (DESKTOP MOUNT TYPE)
NZB-141	CHARGER FOR 6 BATTERIES (WALL MOUNT TYPE)
NZB-142	CHARGER FOR 6 BATTERIES (DESKTOP MOUNT TYPE)

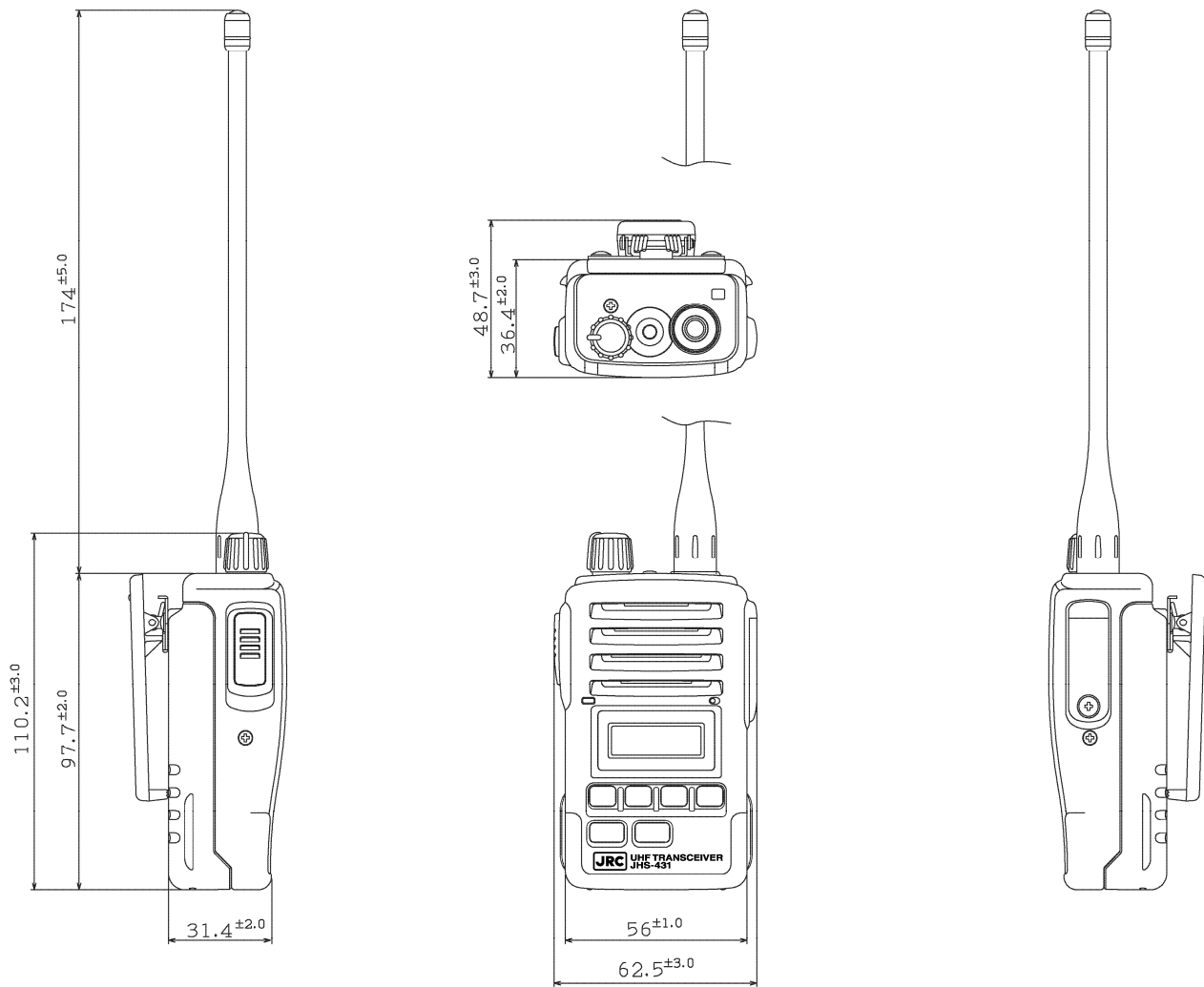

Approx.285g.

JHS-431
UHF TRANSCEIVER
OUTLINE DRAWING

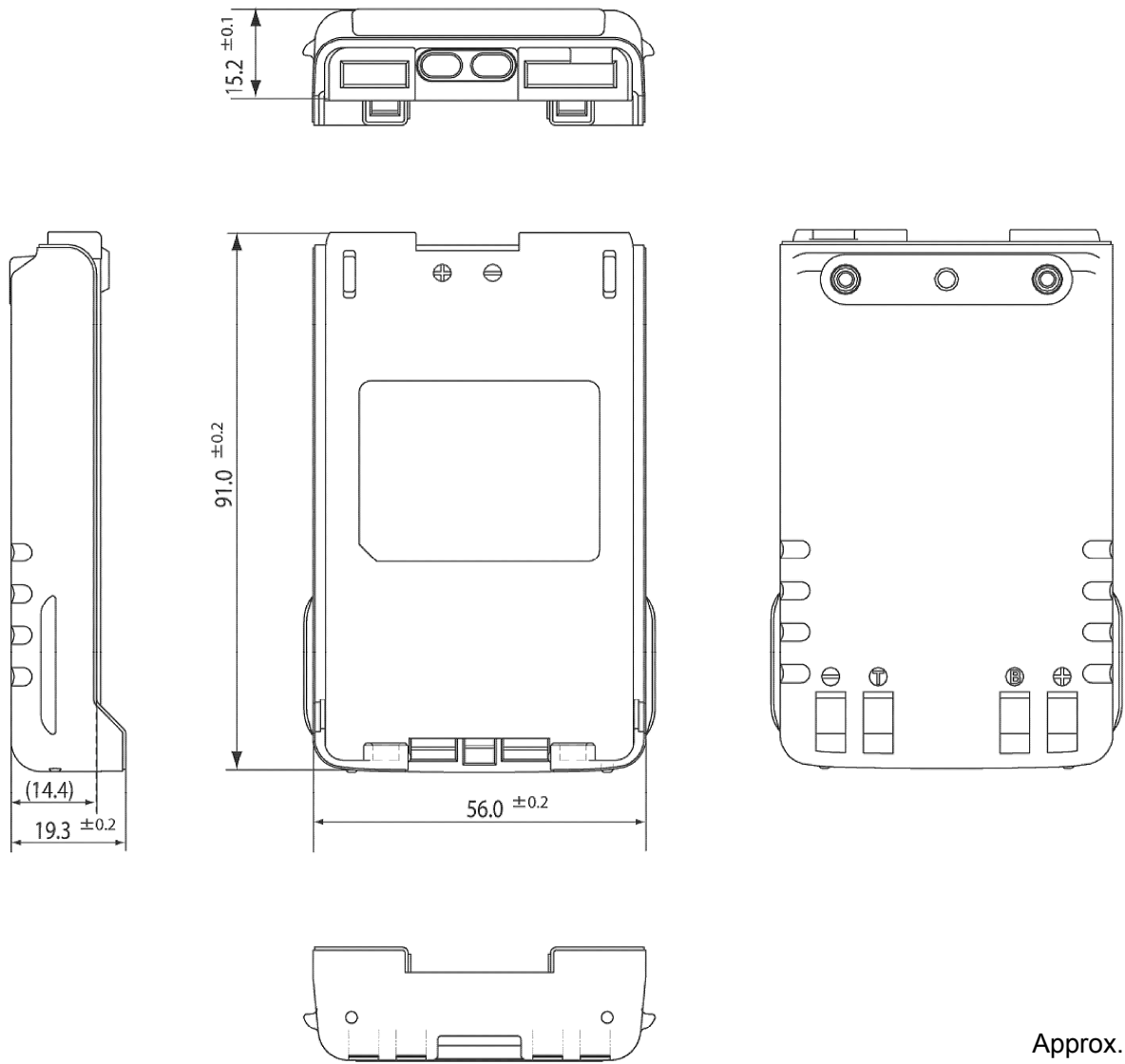

Approx.130g.

BP-227AXD
BATTERY PACK
OUTLINE DRAWING

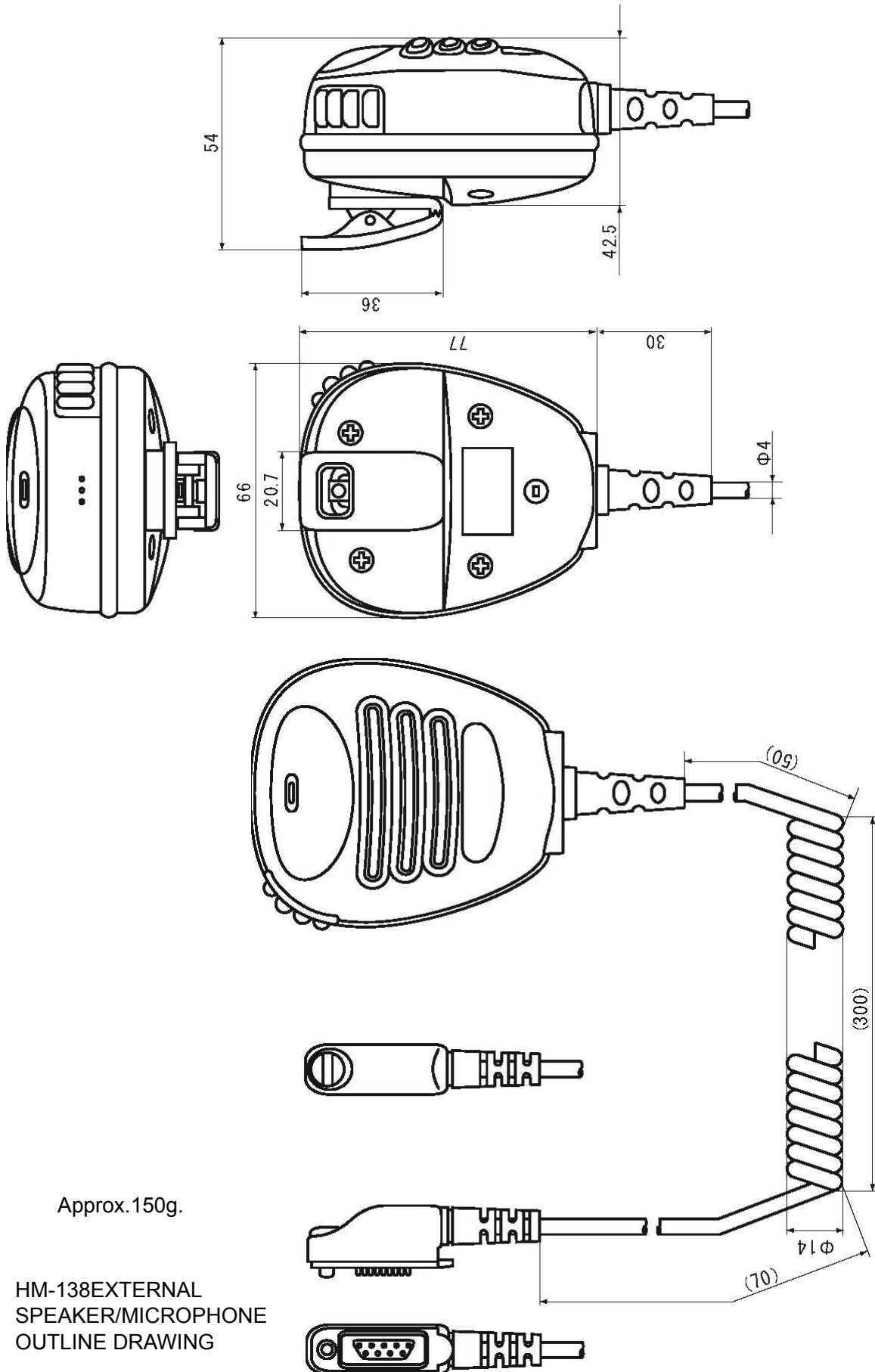

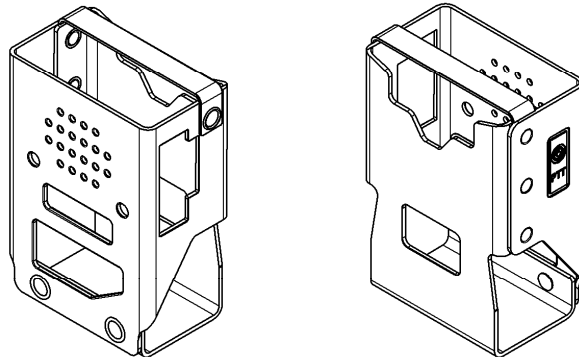
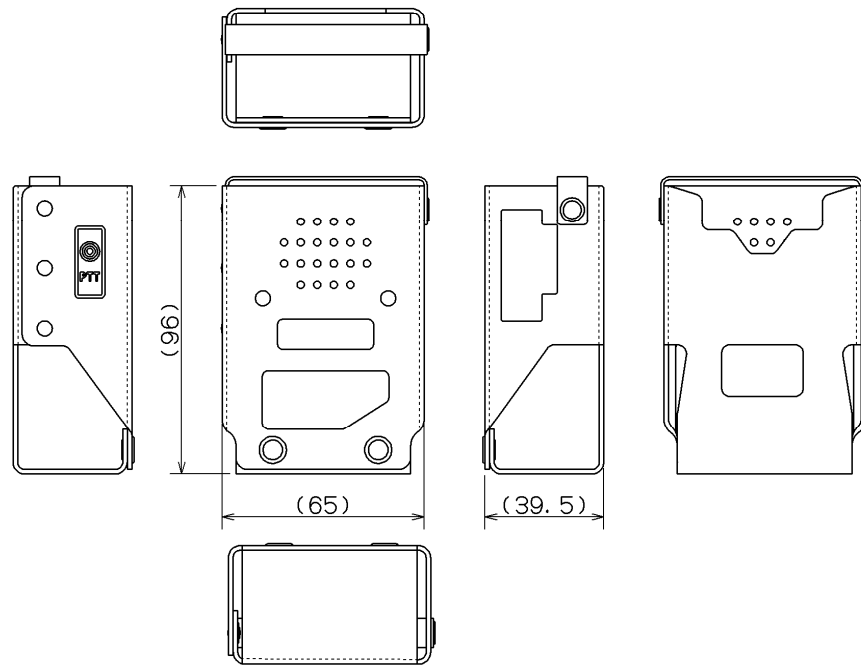

Material: Leather
 Mass: Approx. 20g

MPXP33443A
 CARRYING CASE
 OUTLINE DRAWING

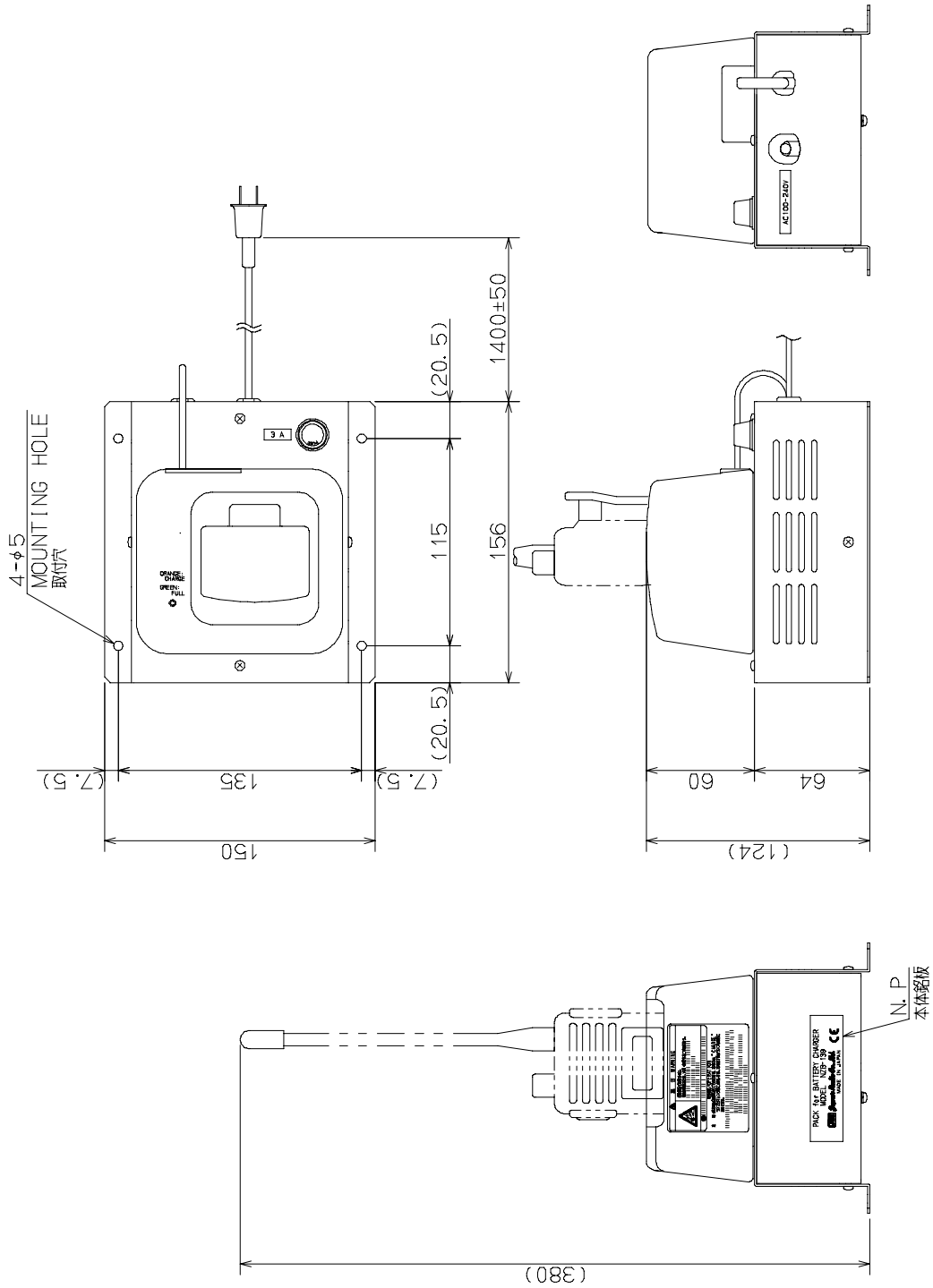

NZB-139
BATTERY CHARGER
(DESKTOP MOUNT TYPE)
OUTLINE DRAWING

Unit : mm
Mass : approx. 1.5 kg
Color : PANTONE 425C (GRAY)

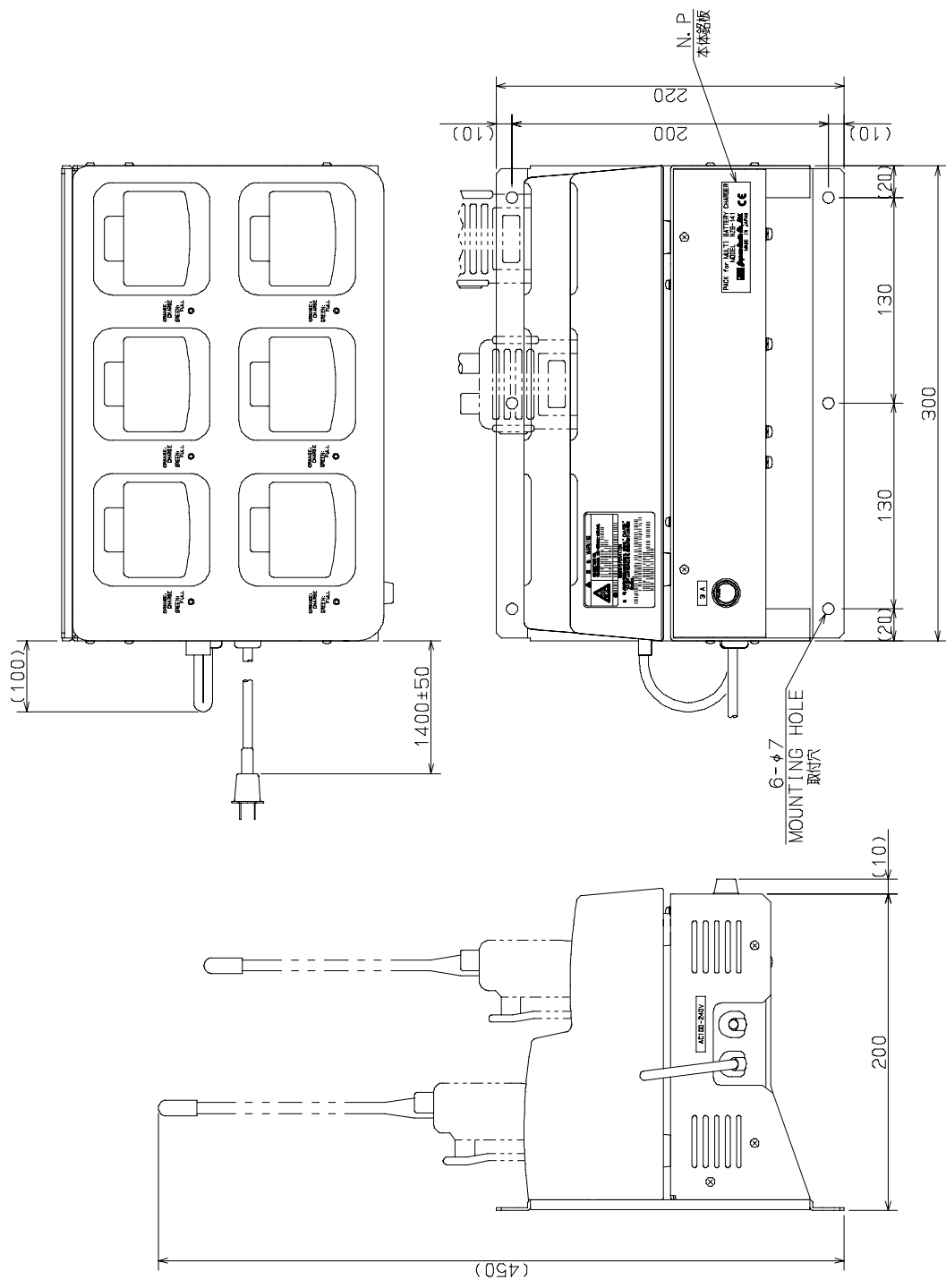

NZB-141
CHARGER FOR 6 BATTERYS
(WALL MOUNT TYPE)
OUTLINE DRAWING

Unit : mm
Mass : approx. 4.0 kg
Color : PANTONE 425C (GRAY)

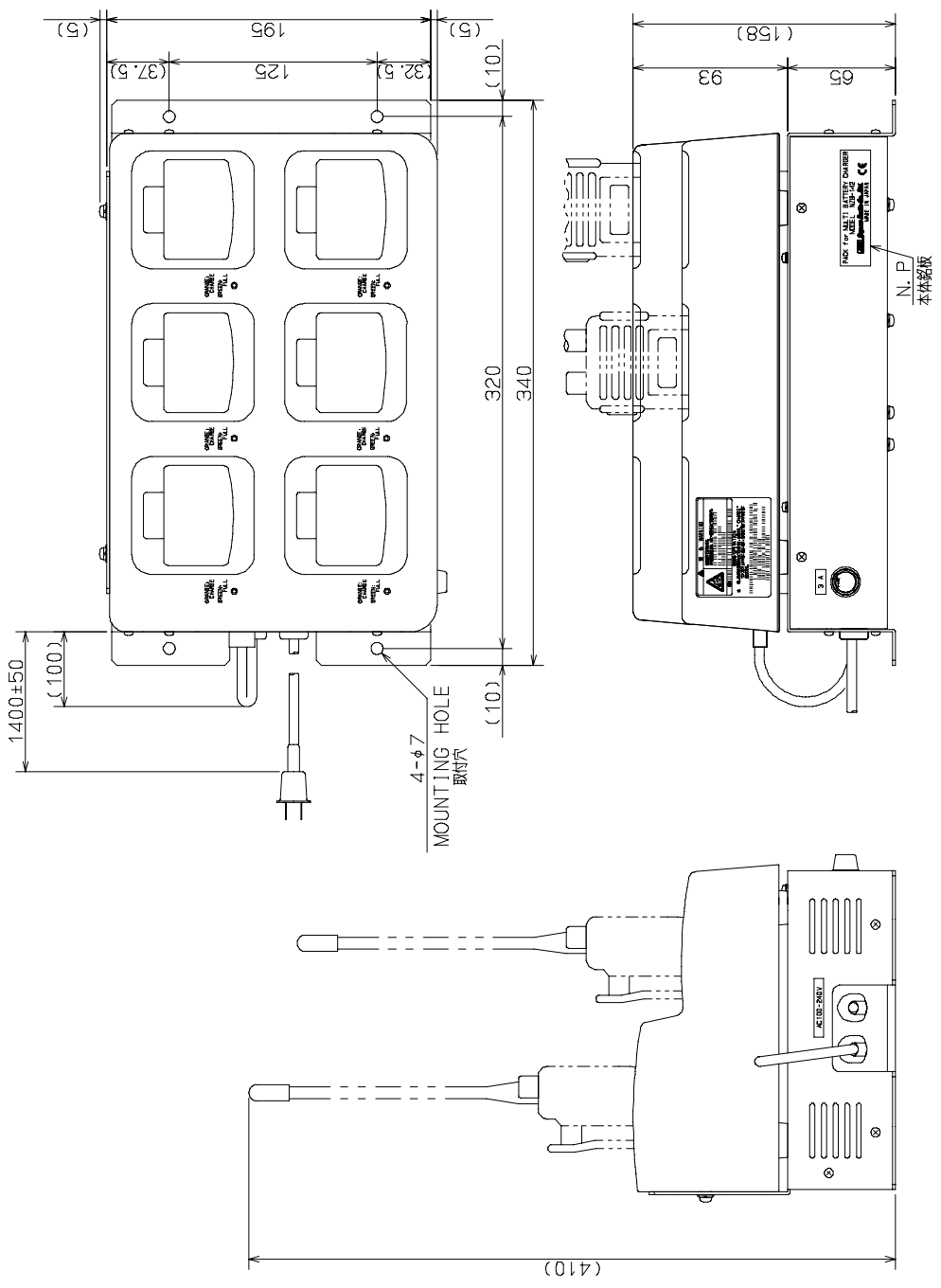

NZB-142
CHARGER FOR 6 BATTERYS
(DESKTOP MOUNT TYPE)
OUTLINE DRAWING

Unit:mm
Mass:approx.4.4kg
Color:PANTONE 425C (GRAY)

电子信息产品有害物资申明
日本无线株式会社

Declaration on toxic & hazardous substances or elements
of Electronic Information Products
Japan Radio Company Limited

有毒有害物质或元素的名称及含量
(Names & Content of toxic and hazardous substances or elements)

形式名(Type): JHS-431

名称(Name): Intrinsically Safe UHF Transceiver

部件名称 (Part name)	有毒有害物质或元素 (Toxic and Hazardous Substances and Elements)					
	铅 (Pb)	汞 (Hg)	镉 (Cd)	六价铬 (Cr ⁶⁺)	多溴联苯 (PBB)	多溴二苯醚 (PBDE)
主要装置 (Main Unit)	×	○	○	○	○	○
外部设备(Peripherals) · 电线类(Cables) · 手册(Documentts)	×	○	○	○	○	○
○: 表示该有毒有害物质在该部件所有均质材料中的含量均在SJ/T11306-2006 标准规定的限量要求以下。 (Indicates that this toxic, or hazardous substance contained in all of the homogeneous materials for this part is below the requirement in SJ/T11363-2006.) ×: 表示该有毒有害物质至少在该部件的某一均质材料中的含量超出SJ/T11363-2006 标准规定的限量要求。 (Indicates that this toxic or hazardous substance contained in at least one of the homogeneous materials used for this part is above the limit requirement in SJ/T 11363-2006.)						



此标志适用于在中华人民共和国境内销售的电子信息产品。标志中的数字表示环保使用期限的年数。在遵守本产品的安全和使用注意事项的前提下，从生产日期至该使用期限，可保证对环境污染和人身财产没有任何影响。

有毒有害物质或元素的名称及含量
(Names & Content of toxic and hazardous substances or elements)

形式名(Type): BP-227AXD

名称(Name): Battery for Intrinsically Safe UHF Transceiver

部件名称 (Part name)	有毒有害物质或元素 (Toxic and Hazardous Substances and Elements)					
	铅 (Pb)	汞 (Hg)	镉 (Cd)	六价铬 (Cr ⁶⁺)	多溴联苯 (PBB)	多溴二苯醚 (PBDE)
电池 (Battery)	×	○	○	○	○	○
○: 表示该有毒有害物质在该部件所有均质材料中的含量均在SJ/T11306-2006 标准规定的限量要求以下。 (Indicates that this toxic, or hazardous substance contained in all of the homogeneous materials for this part is below the requirement in SJ/T11363-2006.) ×: 表示该有毒有害物质至少在该部件的某一均质材料中的含量超出SJ/T11363-2006 标准规定的限量要求。 (Indicates that this toxic or hazardous substance contained in at least one of the homogeneous materials used for this part is above the limit requirement in SJ/T 11363-2006.)						



此标志适用于在中华人民共和国境内销售的电子信息产品。标志中的数字表示环保使用期限的年数。在遵守本产品的安全和使用注意事项的前提下，从生产日期至该使用期限，可保证对环境污染和人身财产没有任何影响。

アスベストは使用していません
Not use the asbestos

CODE No.7ZPJD0566

For further information, contact:

JRC

Since 1915

Japan Radio Co., Ltd.

URL <http://www.jrc.co.jp>

Marine Service Department

Telephone : +81-3-3492-1305

Facsimile : +81-3-3779-1420

e-mail : tmsc@jrc.co.jp

AMSTERDAM Branch

Telephone : +31-20-658-0750

Facsimile : +31-20-658-0755

e-mail : service@jrceurope.com

SEATTLE Branch

Telephone : +1-206-654-5644

Facsimile : +1-206-654-7030

e-mail : marineservice@jrcamerica.com

01ETM

ISO 9001, ISO 14001 Certified

© JUN. 2013

Edition 1

JRC

Printed in Japan